

Raymarine®



REALVISION™

RV-100 3D Transom Transducer
Installation instructions

English (en-US)

Date: 04-2017

Document number: 88067-1

© 2017 Raymarine UK Limited

Important information

Obtain the complete documentation for your product

The supplied printed documentation is a subset of the full documentation available for your product.

Important: The latest versions of all English and translated handbooks are available on the Raymarine website. Please check the website to ensure you have the latest and complete documentation and safety information for your product.

www.raymarine.com/manuals

Certified Installation

Raymarine recommends certified installation by a Raymarine approved installer. A certified installation qualifies for enhanced product warranty benefits. Contact your Raymarine dealer for further details, and refer to the separate warranty document packed with your product.



Warning: Product installation and operation

- This product must be installed and operated in accordance with the instructions provided. Failure to do so could result in personal injury, damage to your vessel and/or poor product performance.
- Raymarine recommends certified installation by a Raymarine approved installer. A certified installation qualifies for enhanced product warranty benefits. Contact your Raymarine dealer for further details, and refer to the separate warranty document packed with your product.



Warning: High voltages

This product may contain high voltages. Do NOT remove any covers or otherwise attempt to access internal components, unless specifically instructed in the documentation provided.



Warning: Switch off power supply

Ensure the vessel's power supply is switched OFF before starting to install this product. Do NOT connect or disconnect equipment with the power switched on, unless instructed in this document.



Warning: Transducer operation

Only test and operate the transducer in the water. Do NOT operate out of water as overheating may occur.

Caution: Service and maintenance

This product contains no user serviceable components. Please refer all maintenance and repair to authorized Raymarine dealers. Unauthorized repair may affect your warranty.

Water ingress

Water ingress disclaimer

Although the waterproof rating capacity of this product meets the stated IPX standard (refer to the product's *Technical Specification*), water intrusion and subsequent equipment failure may occur if the product is subjected to commercial high-pressure washing. Raymarine will not warrant products subjected to high-pressure washing.

Disclaimer

Raymarine does not warrant that this product is error-free or that it is compatible with products manufactured by any person or entity other than Raymarine.

Raymarine is not responsible for damages or injuries caused by your use or inability to use the product, by the interaction of the product with products manufactured by others, or by errors in information utilized by the product supplied by third parties.

Declaration of conformity

Raymarine UK Ltd. declares that this product is compliant with the essential requirements of EMC directive 2004/108/EC.

The original Declaration of Conformity certificate may be viewed on the relevant product page at www.raymarine.com.

Warranty registration

To register your Raymarine product ownership, please visit www.raymarine.com and register online.

It is important that you register your product to receive full warranty benefits. Your unit package includes a bar code label indicating the serial number of the unit. You will need this serial number when registering your product online. You should retain the label for future reference.

Product disposal

Dispose of this product in accordance with the WEEE Directive.



■ The Waste Electrical and Electronic Equipment (WEEE) Directive requires the recycling of waste electrical and electronic equipment.

IMO and SOLAS

The equipment described within this document is intended for use on leisure marine boats and workboats NOT covered by International Maritime Organization (IMO) and Safety of Life at Sea (SOLAS) Carriage Regulations.

Technical accuracy

To the best of our knowledge, the information in this document was correct at the time it was produced. However, Raymarine cannot accept liability for any inaccuracies or omissions it may contain. In addition, our policy of continuous product improvement may change specifications without notice. As a result, Raymarine cannot accept liability for any differences between the product and this document. Please check the Raymarine website (www.raymarine.com) to ensure you have the most up-to-date version(s) of the documentation for your product.

Applicable products

This document is applicable to the following products:

RV-100 RealVision™ 3D Transom Mount Transducer

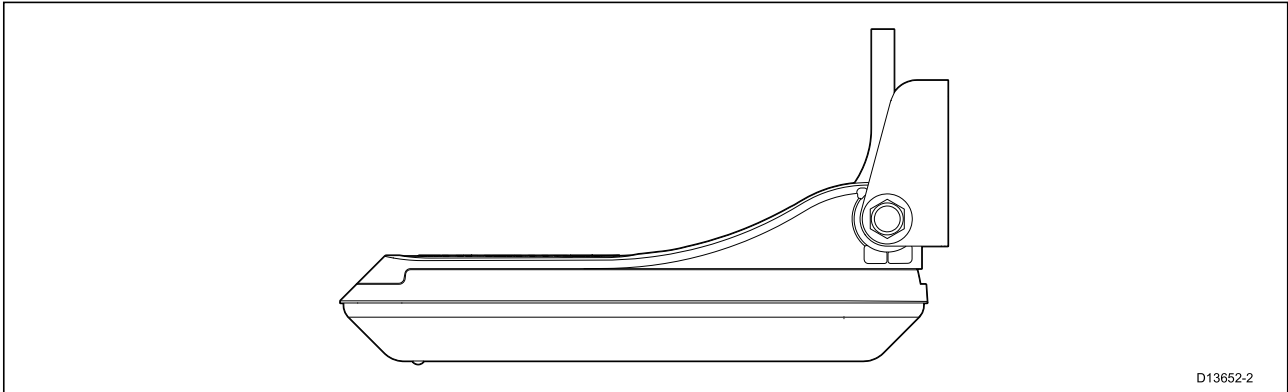

Part number	Description	Construction
A80464	RV-100 RealVision™ 3D Transom Mount Transducer	Plastic

- The **RV-100** is a RealVision™ 3D transducer, capable of producing 3D sonar images.
- The transducer can be connected to RealVision™ 3D variant MFDs running LightHouse™ 3 software.

Note: Additional mounting options are available for the RV-100 RealVision™ 3D transducer. These include:

- Part number A80479: RealVision™ 3D Transducer Step Mount
- Part number A80480: RealVision™ 3D Transducer Jack Plate Mount
- Part number A80482: RealVision™ 3D Transducer Jack Plate Spacer Kit

For further mounting information, refer to the documentation supplied with these products.

Tools required

The following tools are required to install the transducer.

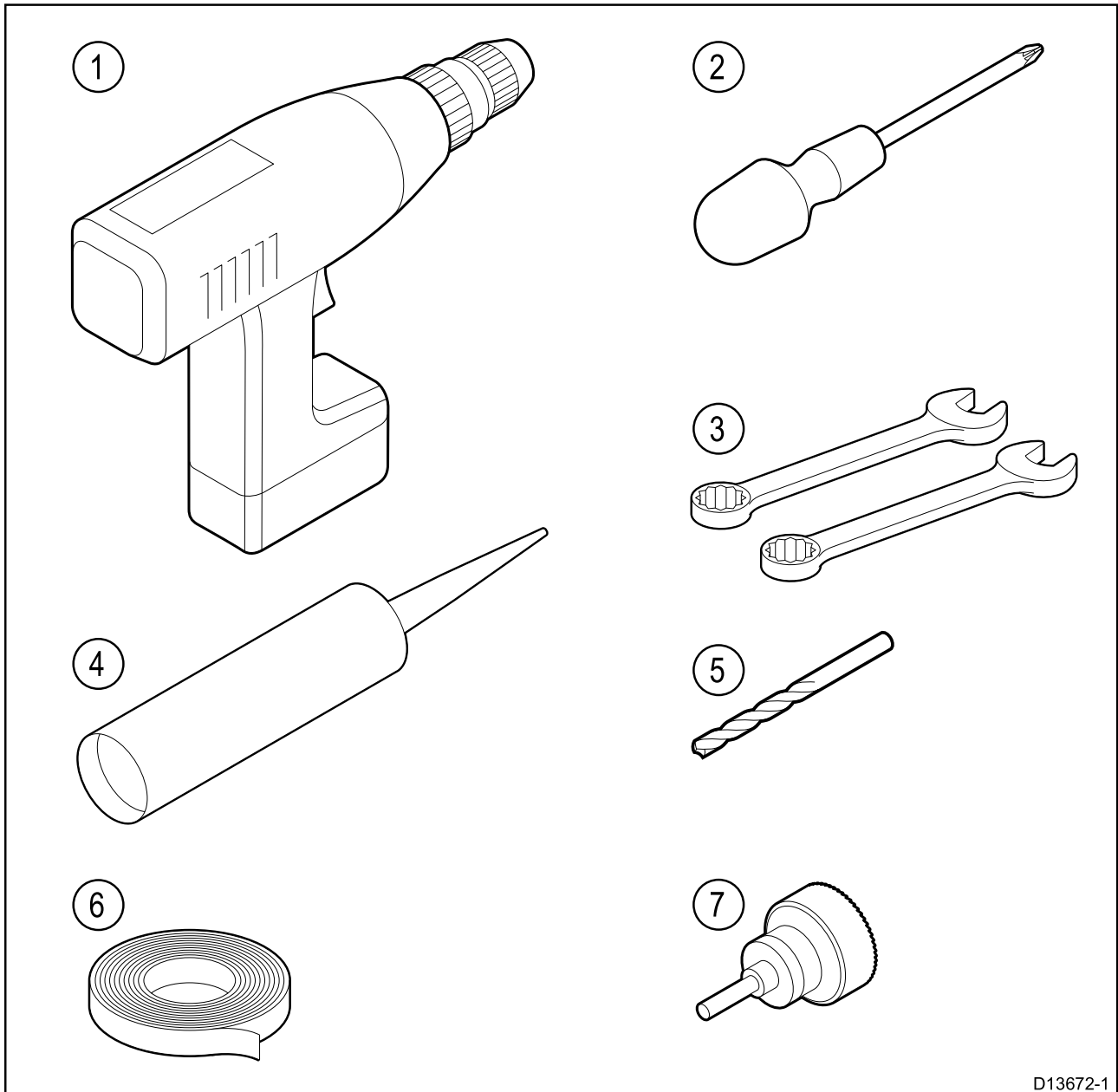

D13672-1

1. Power drill
2. Pozidrive screwdriver
3. Pair of 14 mm wrenches
4. Marine-grade neutral cure polyurethane sealant (non-acetate and non-silicone based)
5. 3.5 mm drill bit *
6. Adhesive tape
7. 25 mm (1 inch) Hole saw (only required if you are routing the cable through a bulkhead.)

Note:

* Depending on the thickness and material of the mounting surface, you may require a different diameter drill bit.

Screws supplied are: stainless-steel tapping DIN 7049-ST, with diameter 4.2 mm (equivalent to a No. 8 screw, diameter 0.164 inch). Three screws of length 18 mm are provided for attaching the mounting bracket; four screws of length 13 mm are provided for attaching the escutcheon plate.



Warning: Marine-grade sealant

Only use marine-grade neutral cure polyurethane sealants. Do NOT use sealants containing acetate or silicone, which can cause damage to plastic parts.

Testing the transducer

Transducer operation should be checked before installation.

1. Connect the transducer to the multifunction display's transducer connection.
2. Fully submerge the transducer in water.
3. Power up the display.
4. Open a Fishfinder application on your display.
5. If required, select the relevant transducer/channel from the Channel selection page (**Menu > Channel**).
6. Check that accurate depth and temperature readings are displayed.
7. If you experience difficulties obtaining readings then contact Raymarine Technical Support.



Warning: Transducer operation

Only test and operate the transducer in the water. Do NOT operate out of water as overheating may occur.

Selecting a location for the transducer

The guidelines below should be followed when selecting a location for the transducer.

Note: The transducer is not suitable for mounting on vessels where the transom is aft of the propeller(s).

For best performance the transducer must be installed in a location with the least turbulence and aeration. The most effective way to determine this is by checking the water flow around the transom whilst underway.

- Mount close to the keel (centerline), in a position where the transducer element will be fully submerged when the vessel is planing and turning.
- Mount a suitable distance from the propeller(s) to avoid wake.
- Mount in a location where no load will be applied to the transducer during launching, lifting, trailering and storage of the boat.

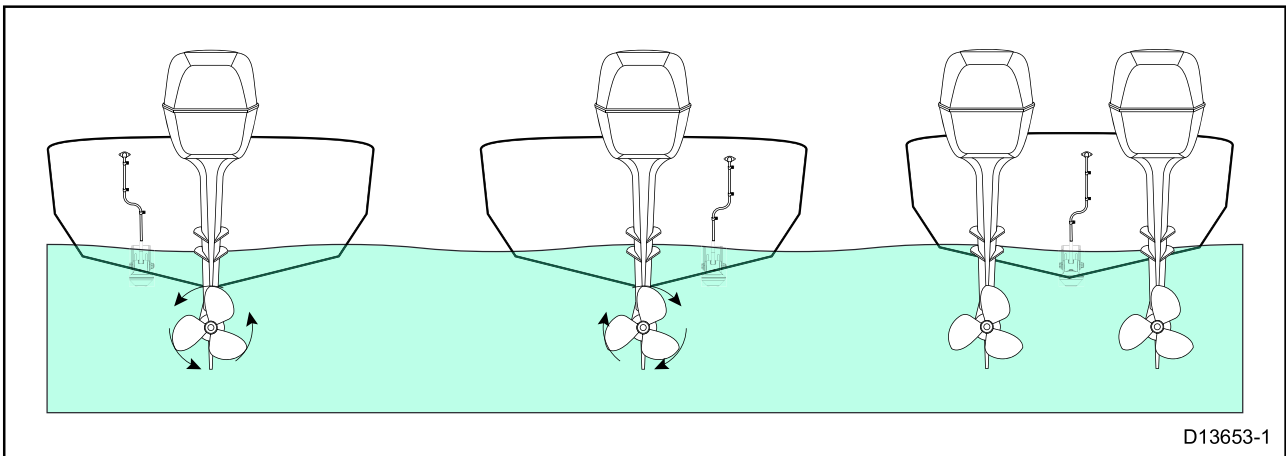

- For clockwise rotating propellers, mount the transducer on the starboard side, for counter-clockwise, mount on the port side.
- On a twin engine vessel mount the transducer between the engines.
- Turbulence can be caused by a number of other factors such as steps (1), ribs (2), rows of rivets (3) and strakes (4). The turbulence appears aft of these locations.

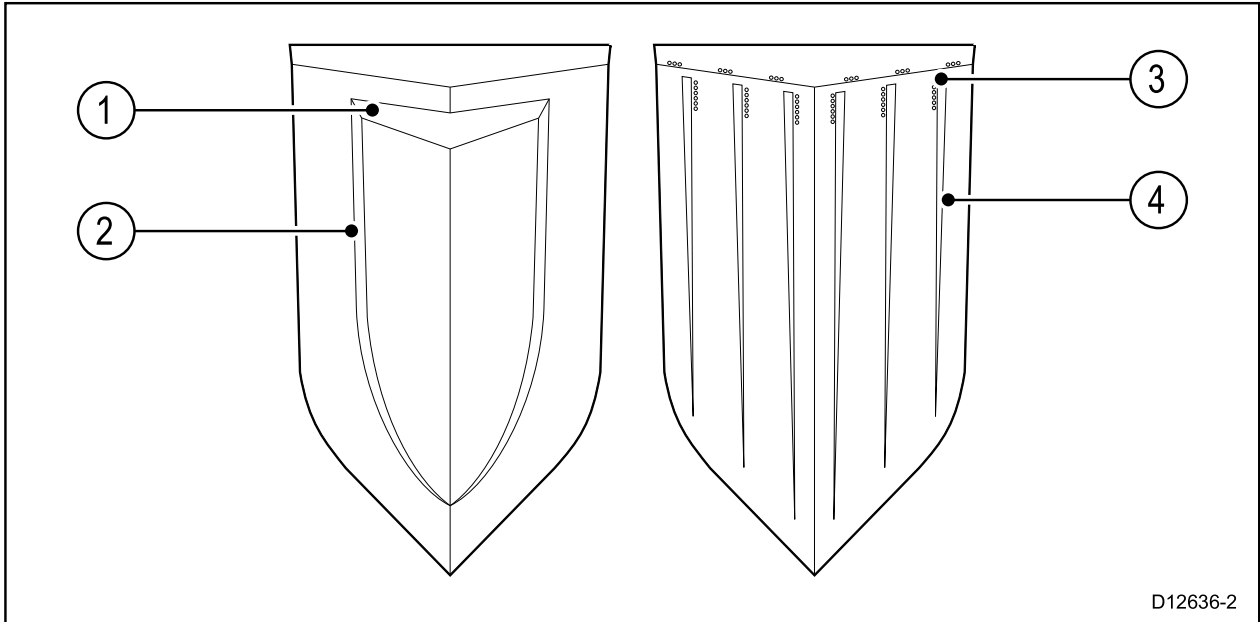

D12636-2

- Air trapped under the front of the vessel can travel under the hull and appear as aeration aft.

Note: Optimum transducer location will vary depending on vessel type. Optimum transducer height and angle should be obtained by testing the transducer with the vessel in the water.

Transducer dimensions — RV-100

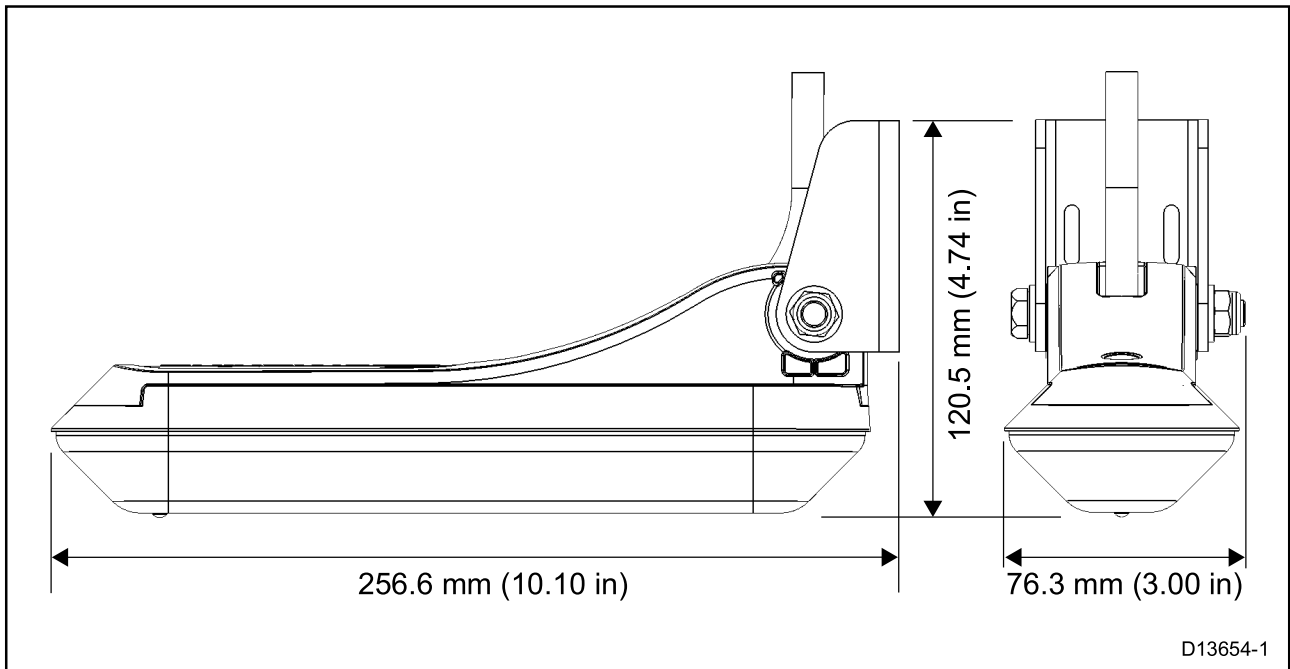

D13654-1

- **RV-100** cable length: 8 m (26.2 ft).

Mounting the transom mount bracket

The transducer must be mounted on the transom using the mounting bracket provided. The steps below describe the initial mounting steps required in order to test your transducers performance. After testing the transducer you must finish the mounting following the instructions in the *Finishing the transducer mounting* section.

1. Fix the transducer mounting template to the selected location, using masking or self-adhesive tape.

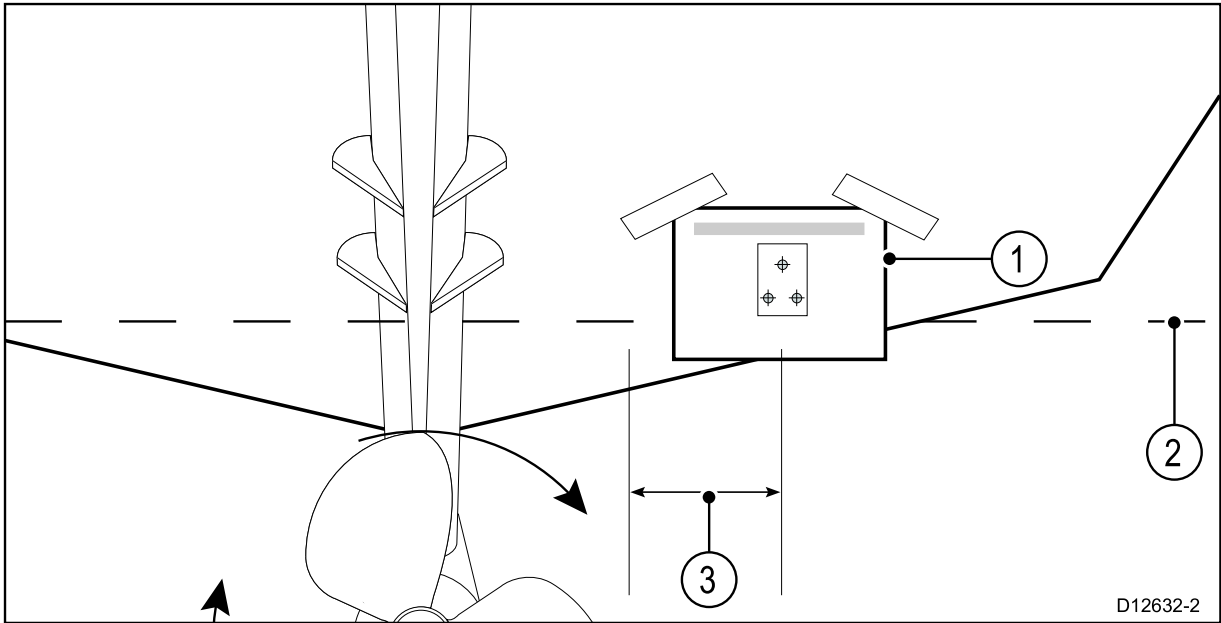

1	Transducer mounting template
2	Waterline
3	Mounting away from propeller

2. Ensure the template is parallel to the waterline.
3. Drill 2 x holes for the adjustment slot screws as indicated on the template.

Note: To help prevent chipping of the mounting surface, use painter's tape to mask the drill area.

Note: Do NOT drill the third mounting hole at this stage.

4. Fill the 2 holes with marine grade sealant.
5. Using a pozi-drive screw driver and the screws provided, secure the transom mount bracket using the 2 adjustment slots.

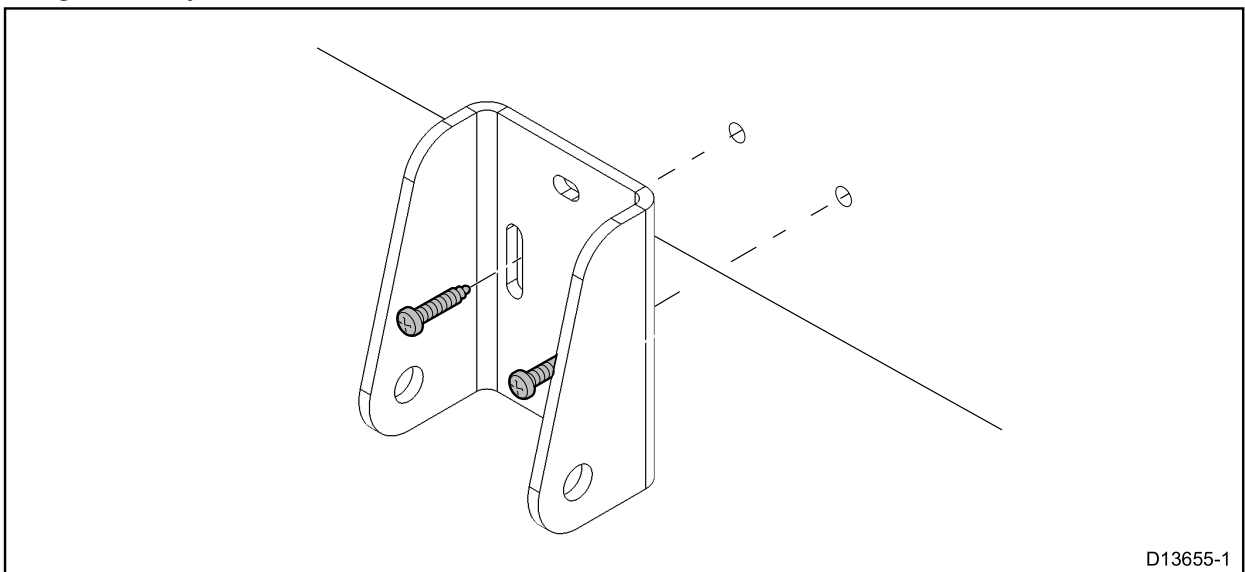

Note: The third locking screw is not used until the transducer has been successfully tested.

Mounting the transducer

The transducer must be mounted on the transom using the mounting bracket provided. The steps below describe the initial mounting steps required in order to test your transducer's performance. After testing the transducer you must finish the mounting following the instructions in the *Finishing the transducer mounting* section.

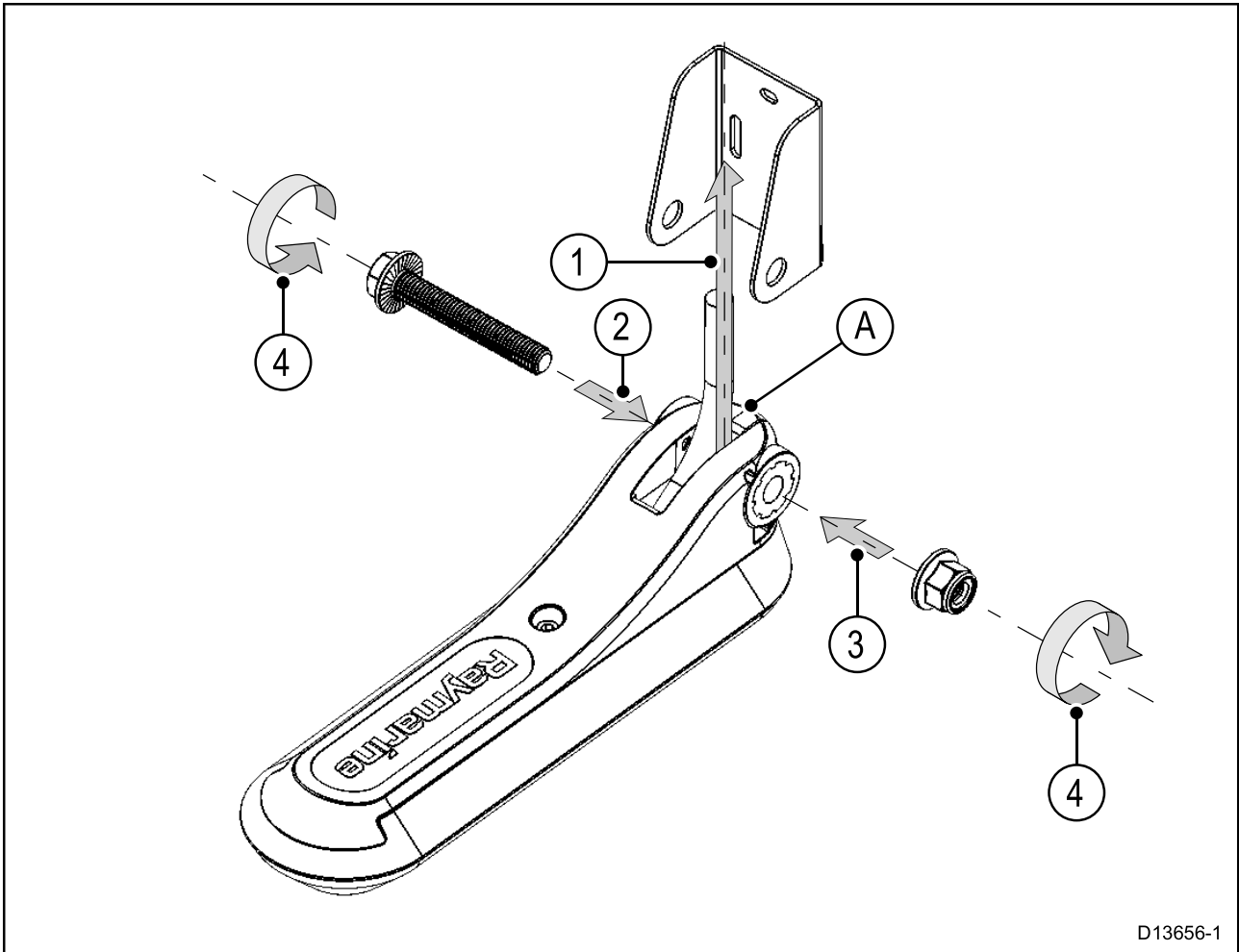

Note: Before starting this procedure, check that the plastic chock (marked 'A' in the illustration) is already positioned in front of the transducer cable. If it is not, push the chock into the correct position, aligning the hole in the chock with the holes in the transducer hanger.

1. Position the transducer hanger between the mounting bracket arms, ensuring that the transducer cable is routed between the arms, and the center hole is aligned with the holes in the arms.
2. Slide the flanged mounting bolt through the mounting bracket assembly.
3. Screw the flanged nyloc nut onto the end of the mounting bolt, and hand-tighten.
4. Using a pair of 14 mm wrenches, tighten the nut onto the mounting bolt until the transducer hanger stays in position, but can still be adjusted by hand.

5. Position the transducer hanger so that the bottom face of the transducer will be parallel with the waterline and tighten the mounting bolt until the hanger is held firmly in place.

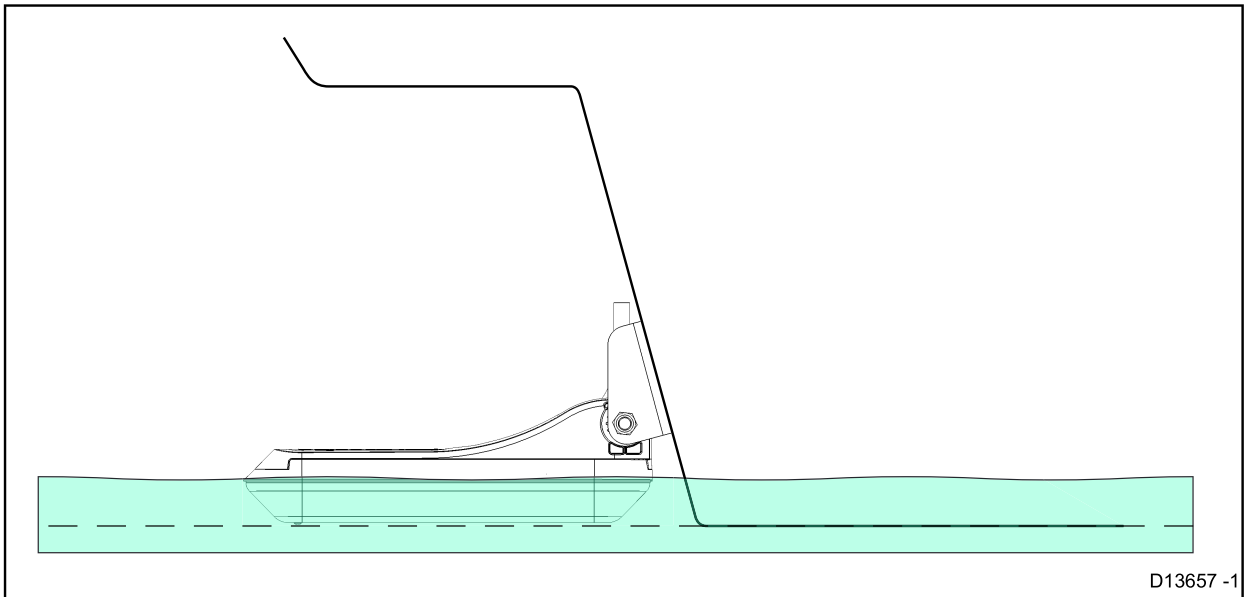

The transducer position will be adjusted further during testing.

Note: Do not adjust the M5 screw located on top of the transducer hanger. This screw locates the transducer correctly on the hanger, and must not be adjusted unless specifically directed to do so (for example, when using the Step Mount accessory).

Cable routing

Cable routing requirements for the transducer cable.

Important: To avoid interference, the cable must be routed as far away from VHF radio antenna cables as possible.

Important: The transducer cable's connector is supplied with a separate locking collar assembly, used to secure the cable firmly to your multifunction display. Ensure that you route the cable all the way to your multifunction display **before** attaching the locking collar.

- Check that the cable is long enough to reach the equipment it will be connected to. The following optional extension cables are available if required:
 - RealVision™ transducer extension cable 3 m (9.8 ft) (part number A80475)
 - RealVision™ transducer extension cable 5m (16.4 ft) (part number A80476)
 - RealVision™ transducer extension cable 8m (26.2 ft) (part number A80477)
- Ensure there is enough slack in the transducer cable, at the transducer end, to allow the transducer to pivot up and down.
- Secure the cable at regular intervals using cable clips (not supplied).
- Any excess cable should be coiled up at a convenient location.

Mounting the escutcheon plate

Your RV-100 transducer is supplied with an escutcheon plate.

If you have chosen to route the transducer cable through the transom or through a bulkhead, you can use the escutcheon plate to cover the hole required to accommodate the cable. The plate is designed to fit over a 25 mm (1 inch) diameter hole.

After you have threaded the transducer cable through the hole in the transom or bulkhead, attach the escutcheon plate as shown, taking care that the cable is not trapped between the escutcheon plate and the mounting surface.

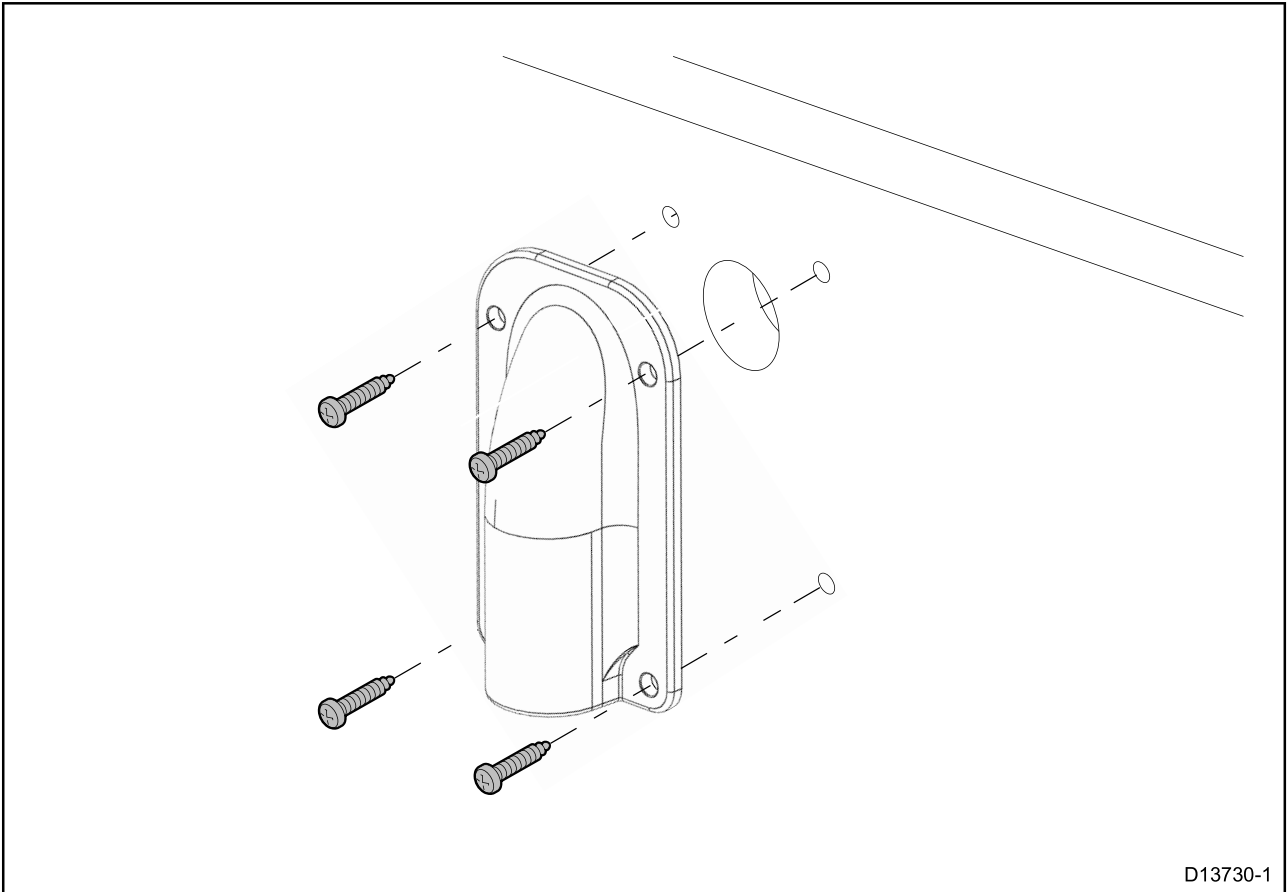

Note: To avoid possible damage to the transducer cable, round-off the edges of the hole that the cable passes through using a file.

Attaching the connector locking collar

The transducer cable's connector is supplied with a separate locking collar assembly, used to secure the cable firmly to your multifunction display.

This procedure describes how to attach the locking collar to the connector. The locking collar parts are supplied in a separate bag, in the box with your transducer.

Important: Ensure that you route the cable all the way to your multifunction display **before** attaching the locking collar.

1. Slide the locking collar over the end of the connector, then push it towards the cable-end of the connector.

Important: Ensure that the lugs on the locking collar (labelled 'A' in the illustration), are closest to the plug-end of the connector.

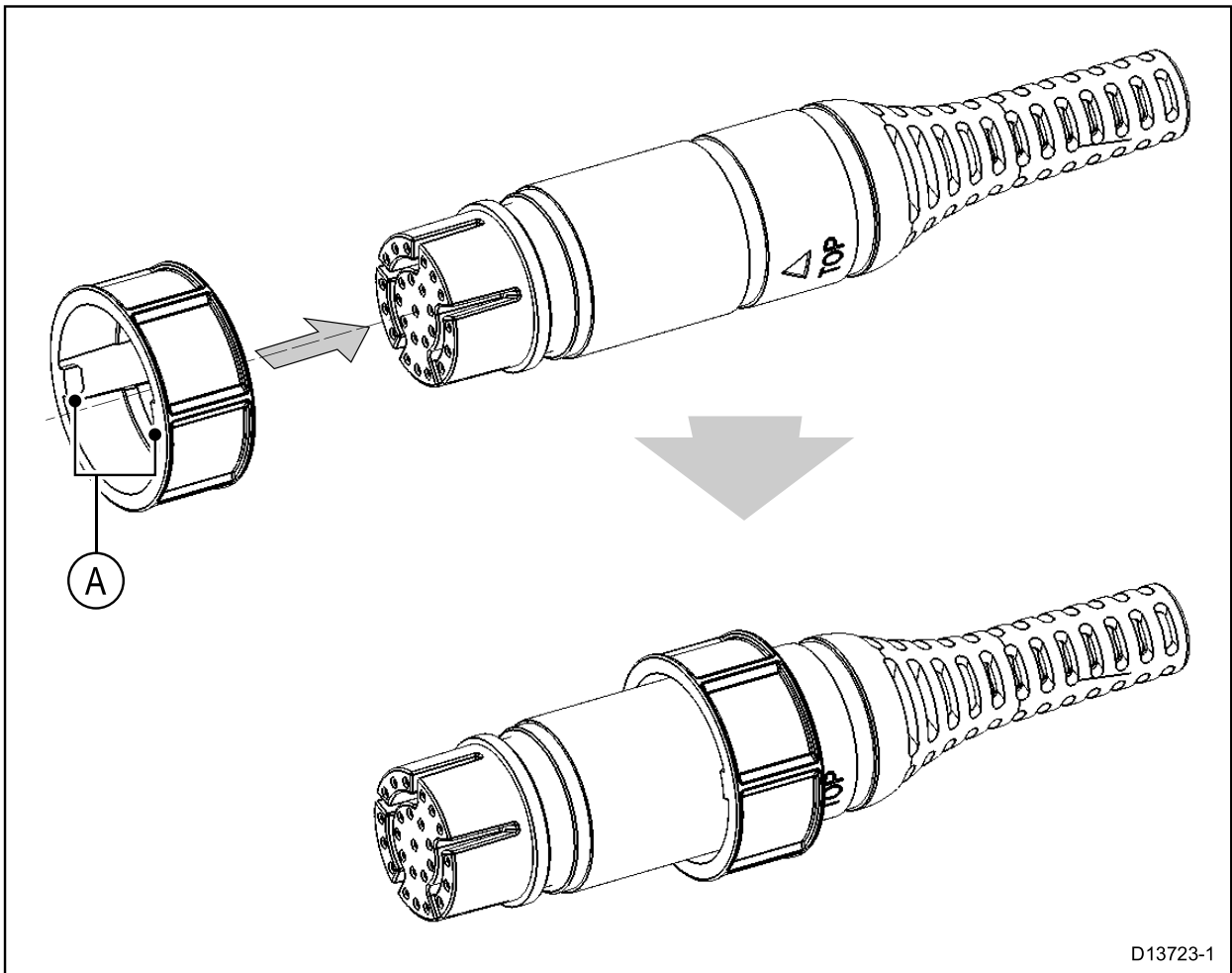

D13723-1

2. Slide the split-ring over the end of the connector, then push it towards the cable-end of the connector.

Important: Ensure that the tabs on the split-ring (labelled 'B' in the illustration), are closest to the cable-end of the connector.

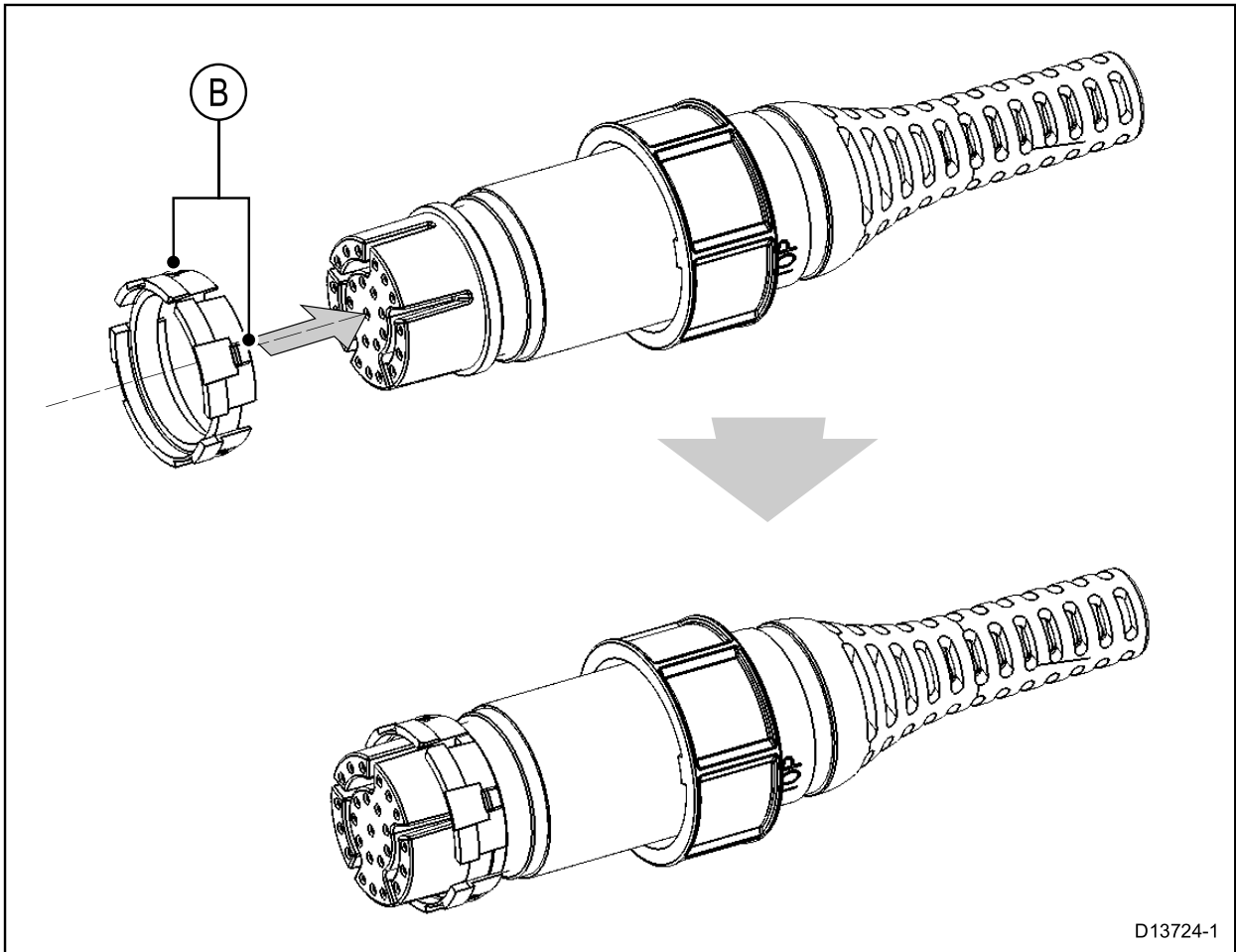

The split-ring slides easily for approximately 1 cm onto the connector, before butting up against the connector moulding.

3. Carefully insert the pointed end of the supplied tool into the split-ring's gap (labelled 'C' in the illustration).

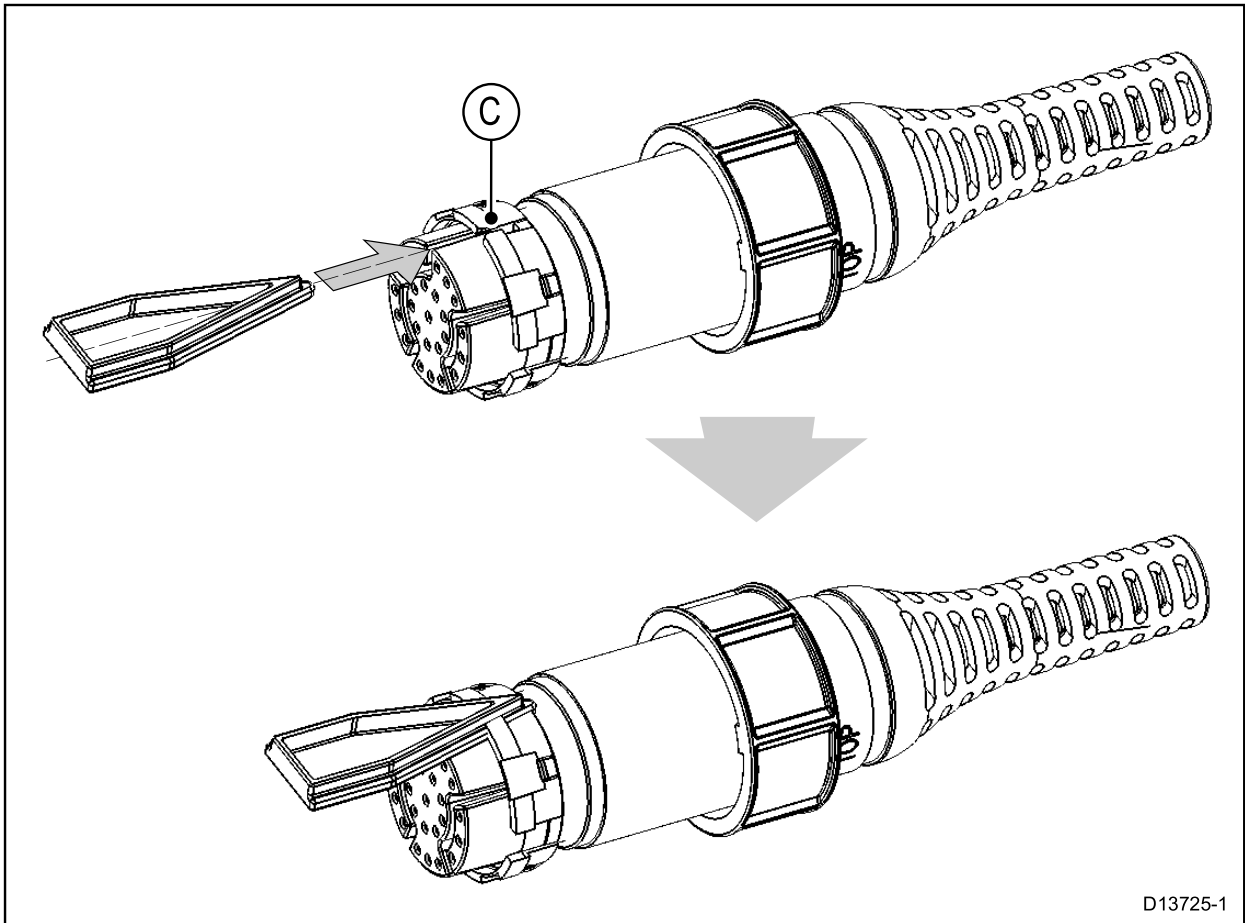

D13725-1

The tool widens the gap in the split ring, enabling the split ring to be pushed further back onto the connector in the following step.

Important: Always use the supplied tool when attaching the split ring. The split ring may become overstretched and break if you try to attach it without using the tool.

4. Use the tool to gently lever the split ring over the moulding on the connector until it snaps into position approximately 0.5 cm further back towards the cable-end of the connector.

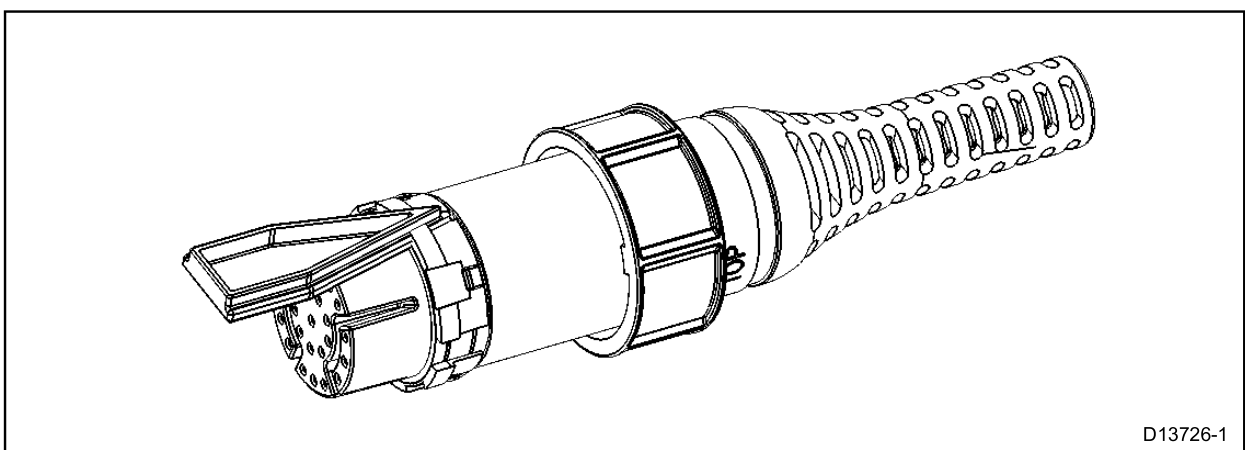

D13726-1

You can now remove the tool. The split-ring stays in position on the connector, but rotates freely.

5. Slide the O-ring over the end of the connector, and ensure that it is seated squarely against the connector moulding, adjacent to the split-ring.

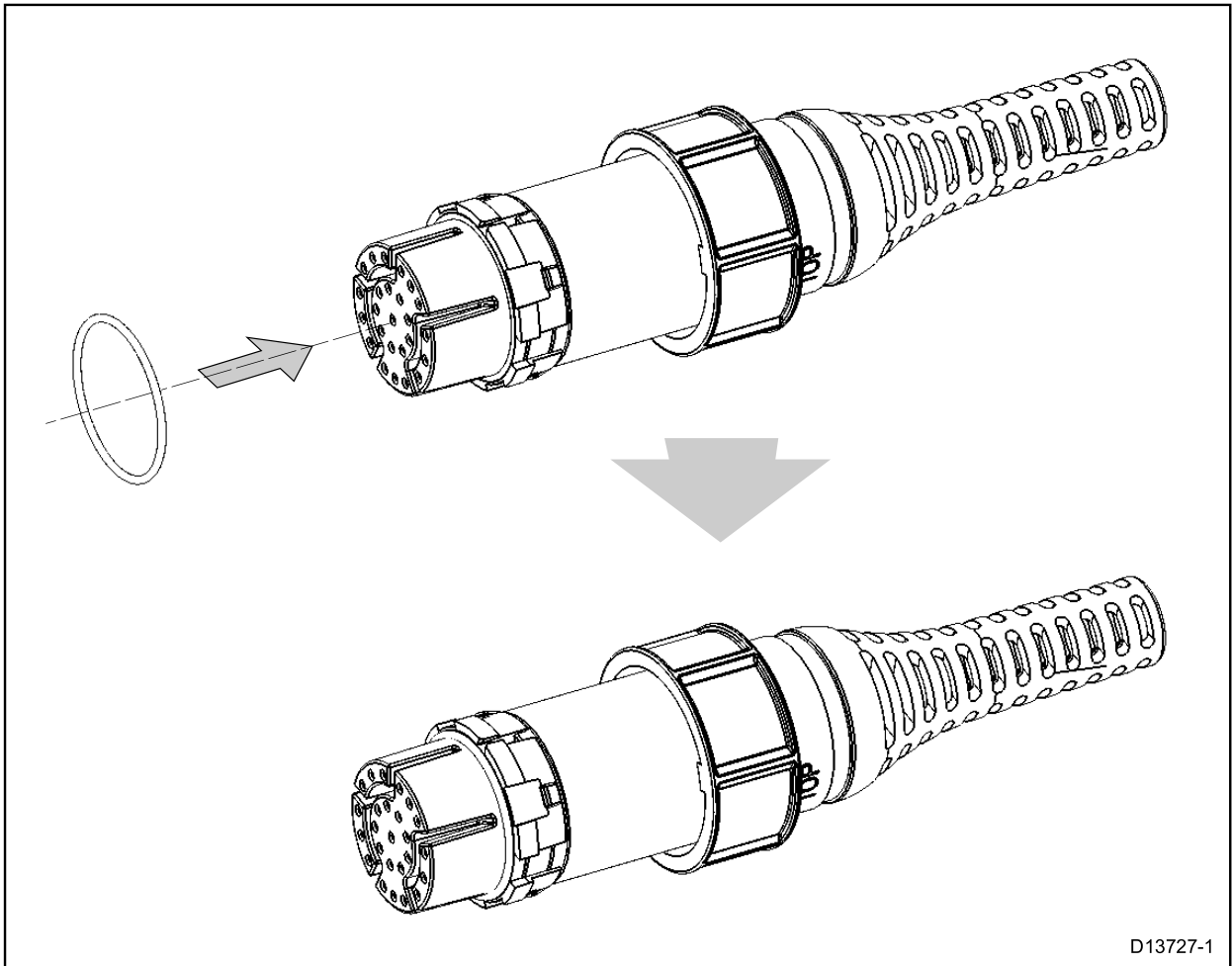

6. Slide the locking collar towards the plug-end of the connector, rotating the collar as necessary to ensure that the lugs on the locking collar (labelled 'D' in the illustration) pass through the channels (labelled 'E') in the split-ring.

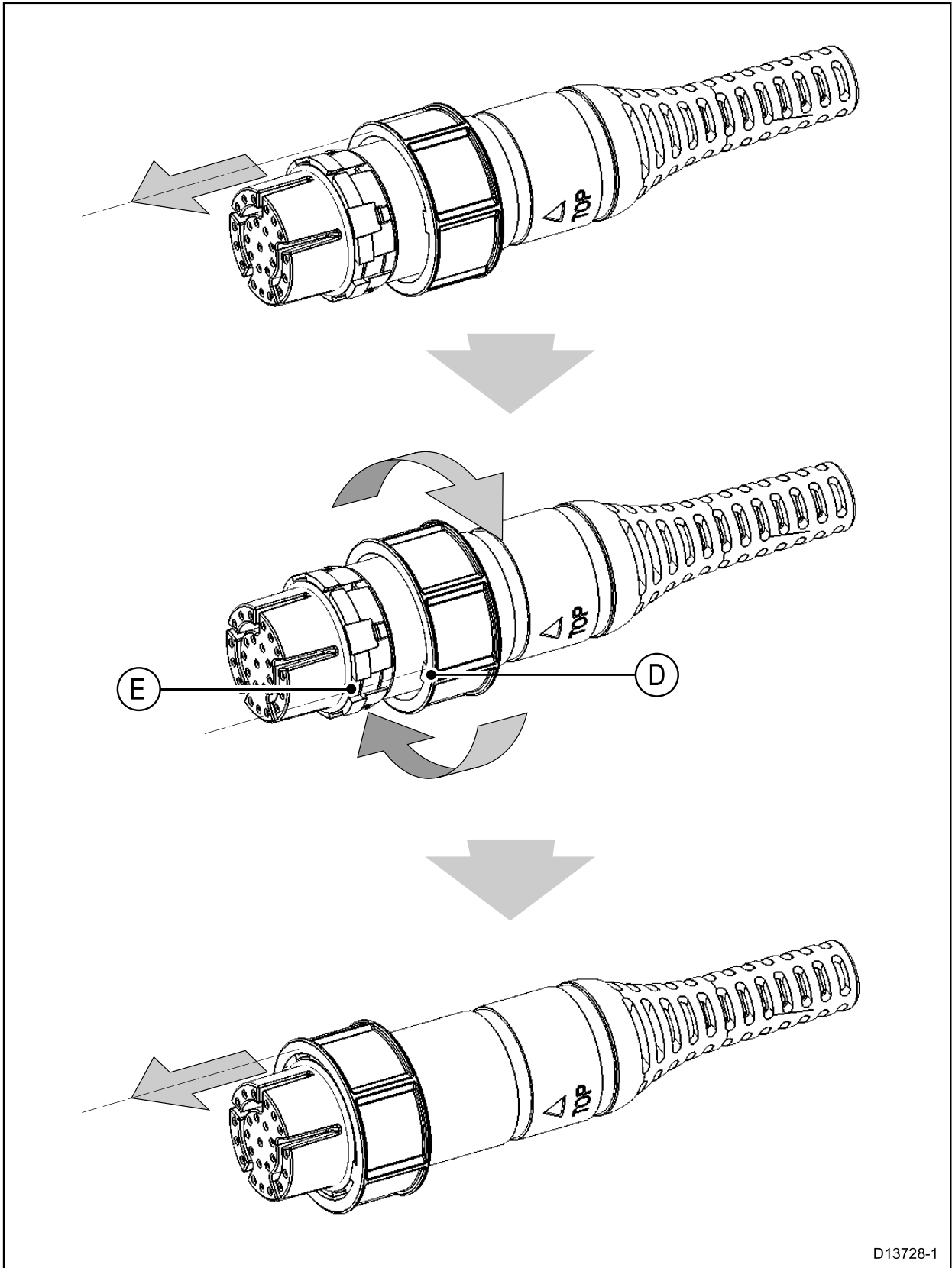

D13728-1

The locking collar slides easily towards the plug-end of the connector, before butting up against the split-ring moulding.

7. Grasp the body of the connector with one hand, then with the other hand, pull the locking collar firmly towards the plug-end of the connector.

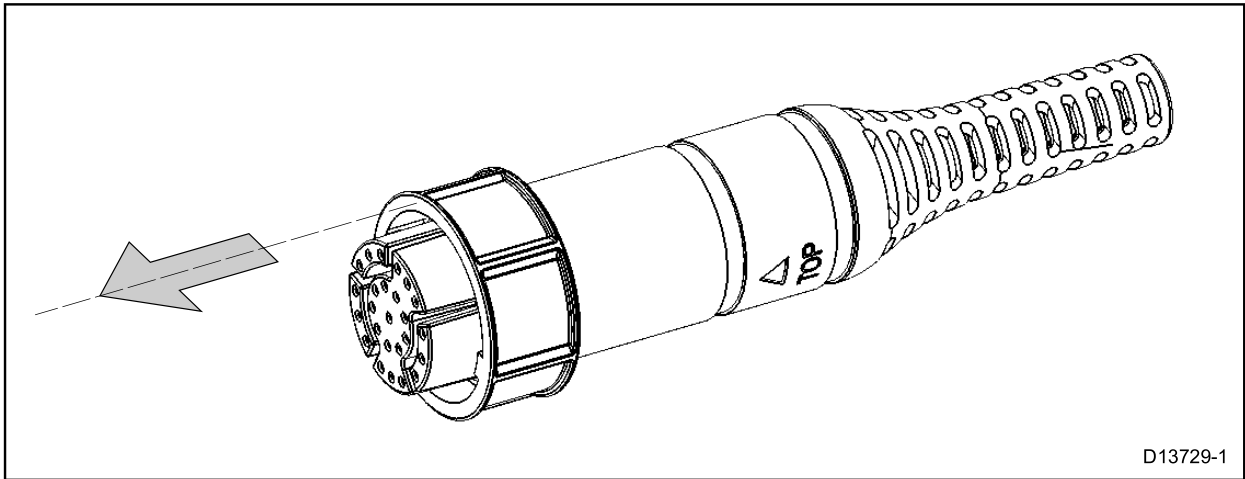

As you pull the locking collar, it clicks into place over the split-ring. The locking collar stays in position on the connector, but rotates freely.

Making connections

Follow the steps below to connect the cable(s) to your product.

1. Ensure that the vessel's power supply is switched off.
2. Ensure that the device being connected to the unit has been installed in accordance with the installation instructions supplied with that device.
3. Ensuring correct orientation, push the cable connector fully onto the corresponding connector on the unit.
4. Turn the locking collar clockwise to secure the cable.

RealVision™ 3D transducer extension cable

For best performance, cable runs should be kept to a minimum. However, for some installations it may be necessary to extend the transducer cable.

- 3 m (9.8 ft), 5 m (16.4 ft), and 8 m (26.2 ft) transducer extension cables are available (part numbers: 3 m - A80475, 5 m - A80476, 8 m - A80477).
- It is recommended that a maximum of two cable extensions are used, with the total cable length not exceeding 18 m.

Testing and adjusting the transducer

Once the initial mounting procedures have been carried out, the transducer must be tested prior to finishing the mounting.

The testing should be carried out with your vessel in the water, with a depth greater than 0.7 m (2.3 ft) but less than the maximum depth range of the transducer.

1. Open the Sonar application on your display, and select the Sonar channel.
After a few seconds the bottom should be visible onscreen and a depth reading displayed.
2. Start moving your vessel at a low speed, ensuring you have a depth reading and a clear image is displayed.
3. Gradually increase the vessel speed whilst checking the display, if the image becomes poor or the bottom is missing at lower speeds then the transducer needs to be adjusted.

4. Angle and height adjustments should be made in small increments and re-tested each time until you obtain optimum performance.

For best performance, you should ensure that the bottom half of the transducer assembly is positioned so that it is lower than the lowest point of the hull in the vicinity of the transducer. In the following illustrations, the dashed line indicates the lowest point of the hull in the vicinity of the transducer.

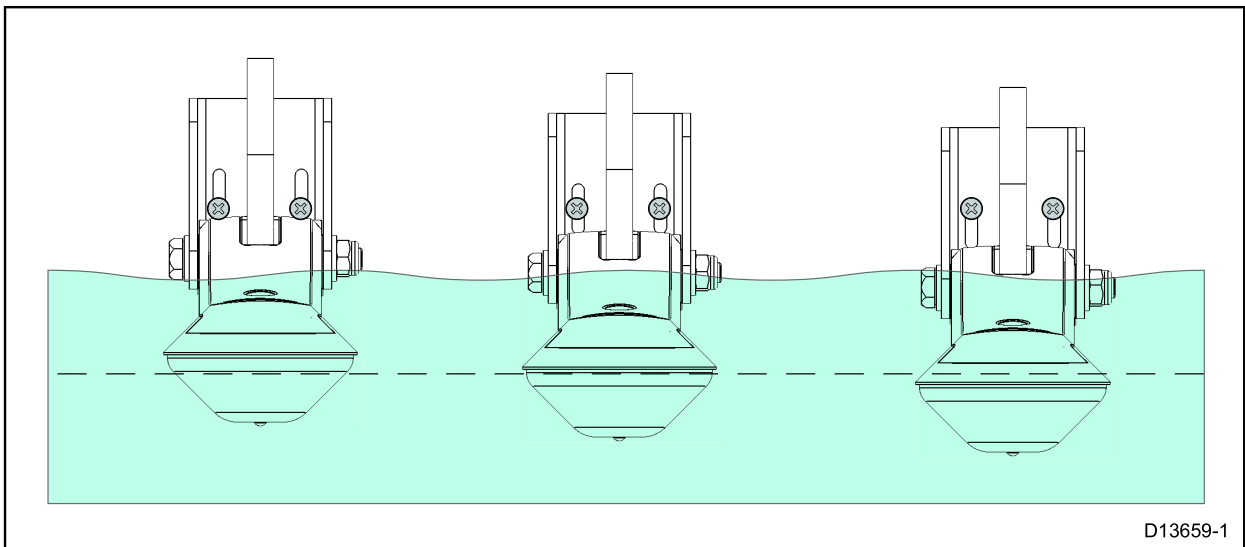
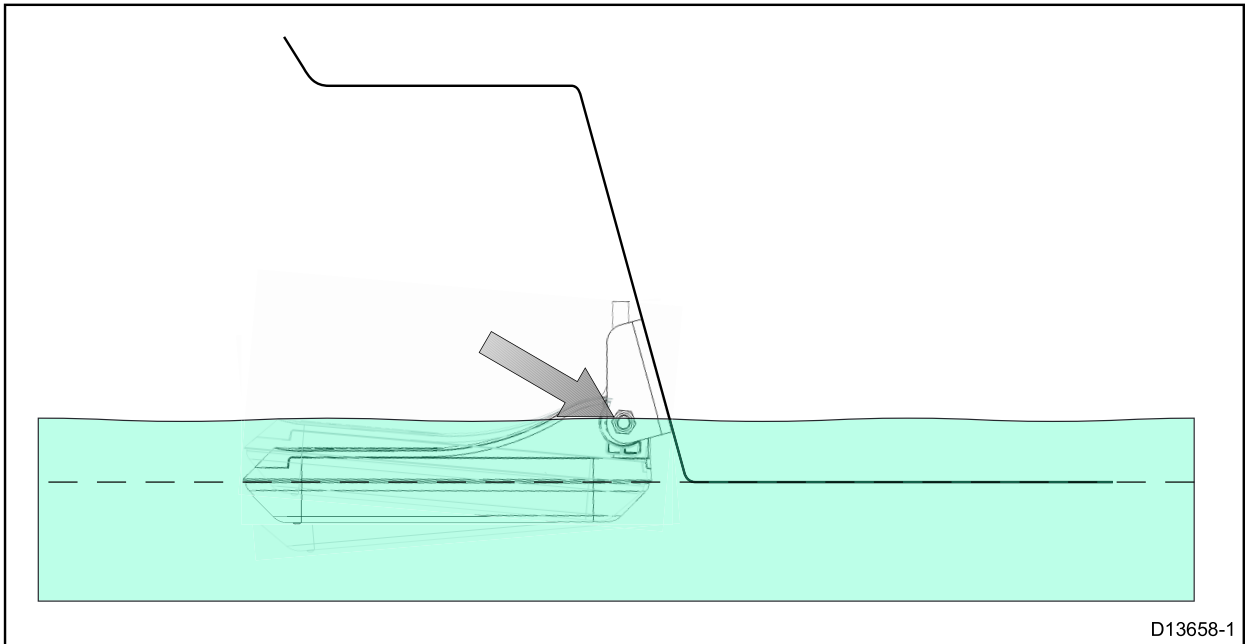

5. Loosen the mounting bolt to adjust the transducer angle.
6. Loosen the 2 mounting bracket screws to adjust the transducer height.
7. Re-tighten the mounting bolt and mounting screws before re-testing.

Note:

- It may not always be possible to obtain depth readings at higher speeds due to air bubbles passing under the transducer.
- It may be necessary to make several adjustments to the transducer before obtaining optimum performance.
- If the transducer requires repositioning ensure all old holes are filled with marine grade sealant.

Finalizing the transducer mounting

Once you have achieved optimum performance at the desired vessel speeds the transducer must be locked into position to complete the installation.



1. Drill the locking hole location taking care not to damage the mounting bracket.
2. Fill the locking hole with marine grade sealant.
3. Secure the transducer and bracket by fully tightening all 3 mounting screws.
4. Secure the transducer hanger by tightening the mounting bolt; do not exceed a torque of 35 Nm (25.8 ft lb). The transducer hanger should not be easily moveable by hand, and should remain in its normal operating position when your vessel is underway.



Raymarine

Marine House, Cartwright Drive, Fareham, Hampshire.
PO15 5RJ. United Kingdom.

Tel: +44 (0)1329 246 700

www.raymarine.com

Raymarine®

a brand by  **FLIR®**